

IHC-200

Plug and Play Humidity Controller



Shenzhen Inkbird Technology Co.,Ltd. support@inkbird.com

Consignor: Shenzhen Inkbird Technology Co., Ltd.

Office Address: Room 1803, Guowei Building, No.68 Guowei Road,
Xianhu Community, Liantang, Luohu District, Shenzhen, China

Manufacturer: Shenzhen Inkbird Technology Co., Ltd.

Factory Address: 6th Floor, Building 713, Pengji Liantang Industrial Area,
No.2 Pengxing Road, Luohu District, Shenzhen, China



V6.0

MADE IN CHINA
DESIGNED BY INKBIRD



Please keep this manual properly for reference. You can also scan the QR code to visit our official website for product usage videos. For any usage issues, please feel free to contact us at **support@inkbird.com**.

Wenn Sie eine Bedienungsanleitung in deutscher Sprache benötigen, scannen Sie bitte den QR-Code und besuchen Sie unsere Website, um sie zu erhalten und ein Video über die Verwendung des Produkts zu sehen.

Se avete bisogno di un manuale di istruzioni in italiano, scansionate il codice QR e visitate il nostro sito web per ottenerlo e vedere un video su come utilizzare il prodotto.

Si vous avez besoin d'un mode d'emploi en français, veuillez scanner le code QR pour visiter notre site officiel afin d'obtenir et de visionner la vidéo d'utilisation du produit !

Als je een Nederlandstalige handleiding nodig hebt, scan dan de QR-code om naar onze officiële website te gaan en bekijk de video over het gebruik van het product!

Si necesita el manual de instrucciones en español, escanee el código QR para ir a nuestro sitio web oficial y ver el vídeo sobre cómo utilizar el producto.



Warm tips

- To quickly jump to a specific chapter page, click on the relevant text on the contents page.
- You can also use the thumbnail or document outline in the top left corner to quickly find a specific page.

Contents

1. Introduction	2
What is IHC-200?	2
Main Features	2
2. Specifications	2
3. Device layout and functions	3
4. Basic Operation	4
4.1 Power On/Off	4
4.2 Enquiry Differential Value	4
4.3 Enquiry Measuring Humidity	4
4.4 How to Set Parameters	4
4.5 Setup Flow Chart	5
5. Settings	5
5.1 Humidity Control Range Setting (HS, HD, DD)	6
5.2 Alarm High/Low Limit Setting (AH, AL)	6
5.3 Compressor Delay (PT)	6
5.4 Humidity Calibration (CA)	6
6. Error Description	7
7. Technical Assistance and Warranty	7
7.1 Technical Assistance	7
7.2 Warranty	7
8. Troubleshooting Guide	8

Safety Precautions

- Please read specification carefully before using product.
- Do not touch the terminals at least while power is being supplied. This could lead to electric shock.
- Do not allow pieces of metal, wire clippings, or fine metallic shaving or filings from installation to enter the product. This can result in electric shock, fire, or malfunction.
- Keep the product away from heat sources such as fires, flammable or explosive gas etc. This may lead to the generation of excessive heat, ignition and explosion.
- Never disassemble, modify or repair the product or touch any of the internal parts. This can result in electric shock, fire, or malfunction.
- If the output relays are used over their life expectancy, contact fusing or burning may occasionally occur. Always consider the application conditions and use the output relays within their rated load and electrical life expectancy. Do not immerse product in water/ seawater.

1. Introduction

What is IHC-200?

IHC-200 is an easy-to-use, safe and reliable dual relay output humidity controller. Its play-n-plug designed, dual LED screens enabling more humanized. IHC-200 can control any 100-265 volt humidifier, dehumidifier or fan.

Main Features

- Switch the modes between humidification and dehumidification automatically;
- Control humidity by setting value and differential value;
- Calibrate the humidity value;
- Delay protection for control output;
- Query current humidity;
- Alarm when humidity exceeds high/low humidity setting value;
- Alarm when sensor error or humidity exceeds limit;

2. Specifications

Power Input	100 ~240VAC, 50Hz/60Hz
Power Output	Max. 10A, 100V ~240V AC
Power Consumption	<3W
Humidity Measuring Range	5% -99,99%RH
Humidity Control Range	5% -99%RH
Resolution	0,1%RH
Accuracy	±3%RH
Sensor Model	HTG3535CH
Sensor Stability	<0.5%RH/yr
Sensor Length	2m / 6.56ft
Relay Contact Capacity	Humidification (12A, 100 -240VAC)
	Dehumidification (12A, 100 -240VAC)
Input Power Cable Length	1,5m (5ft)
Output Power Cable Length	30cm (1ft)
Dimension	Main Body: 140x68x33mm (5,5x2,7x1,3 inch) Socket (US Version) : 85x42x24mm (3,3x1,7x1,0 inch) Socket (EU Version) : 135x54x40mm (5,3x2,1x1,6 inch) Socket (UK Version) : 140x51x27mm (5,5x2,0x1,0 inch)
Ambient Temperature	-30~ 75 °C / - 22~ 167 °F
Storage	Temperature -30~ 75 °C / -22~ 167 °F
	Humidity 20~85% (No Condensate)
Warranty	1 Year

3. Device layout and functions

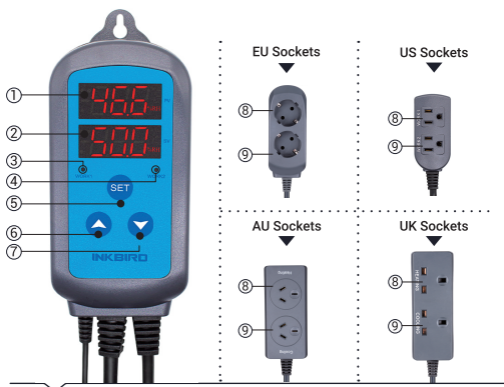

① PV: Process Value.

- Under running mode, display current humidity;
- Under setting mode, display menu code;
- When pressing the decrease and increase keys simultaneously it displays the current humidity.

② SV: Setting Value.

- Under running mode, display setting humidity;
- Under setting mode, display setting value.

③ Humidification Indicator Lamp:

- On: Humidification Working;
- Off: Humidification Stop Working.

④ Dehumidification Indicator Lamp:

- On, Dehumidification Working;
- Off, Dehumidification Stop Working;
- Flicker, Dehumidification Delay.

⑤ SET key :

- Press SET key for 3 seconds to enter menu for function setting. During the setting process, press SET key for 3 seconds to quit and save setting changes.

⑥ DECREASE key :

- Under running mode, press DECREASE key to inquiry DD value; Under setting mode, press DECREASE key to decrease value.

⑦ INCREASE key :

- Under running mode, press INCREASE key to inquiry HD value; Under setting mode, press INCREASE key to increase value.

⑧ Humidification Device Socket: Humidification output.

⑨ Dehumidification Device Socket: Dehumidification output.

4. Basic Operation

4.1 Power On/Off

When the controller is working normally, press and hold "SET" "▲" "▼" key simultaneously for 3 seconds to enter the condition of power off, all the display and output would be turn off. On the condition of power off, press and hold "SET" "▲" "▼" key simultaneously for 1 second to enter the condition of normal measuring.

4.2 Enquiry Differential Value

When the controller is working normally, short press "▲" key once, then the humidification differential (HD) will be displayed; Short press "▼" once, then the dehumidification differential (DD) will be displayed. Two seconds later, the display of humidity will be return to the normal display mode.

4.3 Enquiry Measuring Humidity

Press "▲" and "▼" key simultaneously to display the current humidity value on PV screen. Release the key for 2 seconds to return to the normal display mode.

4.4 How to Set Parameters

When the controller is working normally, press and hold the "SET" button to set the parameters, the PV screen will display the first menu code "HS" and the SV screen will display the setting value.

Press "SET" key to page down the menu then the code would be displayed, press "▲" "▼" key to change the current parameter

values.

After finished settings, press and hold "SET" key for 3 seconds at any status to save the parameter setting value and return to the normal displaying mode of humidity. During setting, if there is no operation for 10 seconds, system will quit the menu automatically and return to the mode of normal humidity displaying without saving the parameters modification.

4.5 Setup Flow Chart

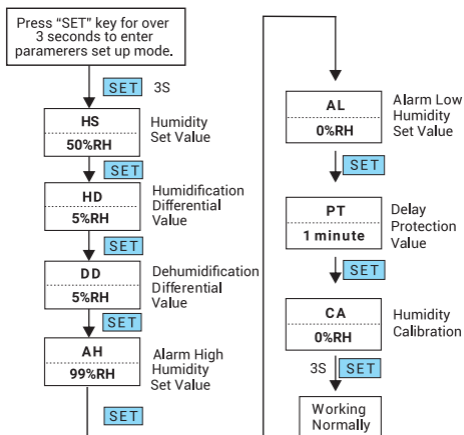

5. Settings

Menu Code	Function	Setting Range	Default	Unit	Remarks
HS	Humidity Set Value	5 ~ 99	50	%RH	5.1
HD	Humidification Differential Value	1 ~ 20	5	%RH	5.1
DD	Dehumidification Differential Value	1 ~ 20	5	%RH	5.1
AH	Alarm High Humidity Set Value	50 ~ 99	99	%RH	5.2
AL	Alarm Low Humidity Set Value	0 ~ 50	0	%RH	5.2
PT	Delay Protection Value	0 ~ 10	1	minute	5.3
CA	Humidity Calibration	-10 ~ 10	0	%	5.4

5.1 Humidity Control Range Setting (HS, HD, DD)

When controller works normally, LED displays current measured value of humidity, then starting the recognition and translation of humidifying and dehumidifying automatically.

When the measured humidity $PV \geq HS$ (**Humidity Set Value**) + **DD** (**Dehumidification Differential Value**), entering into the status of dehumidification, indicator lamp of dehumidification will on, relay of dehumidification will work. **When the dehumidification indicator light is flickering**, the dehumidifying equipment is being in the status of delay protection. When the measured humidity $PV \leq HS$ (**Humidity Set Value**), the dehumidification indicator lamp will off, and the dehumidification relay stops working.

When the measured humidity $PV \leq HS$ (**Humidity Set Value**) – **HD** (**Humidification Differential Value**), entering into the status of humidification, indicator lamp of humidification will on, relay of humidification will work; When the measured humidity $PV \geq HS$ (**Humidity Set Value**), indicator lamp of humidification will off, the humidification relay stops working.

5.2 Alarm High/Low Limit Setting (AH, AL)

When PV (the Measured Humidity Value) $\geq AH$ (Alarm High Humidity Set Value) or PV (the Measured Humidity Value) $\leq AL$ (Alarm Low Humidity Set Value), the alarm will make a beeping sound, the current value and AH/AL will display on the PV screen. Press any button will stop the alarm sound, but the alarm status will not change until the measured humidity value back to the set range.

5.3 Compressor Delay (PT)

When the controller is in dehumidification mode, it won't start dehumidification but will wait for a delay time if PV (the Measured Humidity Value) $\geq HS$ (Humidity Set Value) + **DD** (Dehumidification Differential Value).

When the time interval between two dehumidification operation (or the time from power on to dehumidify) is larger than preset delay, the equipment will start dehumidification immediately; when the time interval between two dehumidification (or the time from power on to dehumidify) is less than preset delay, the equipment won't start dehumidification until preset delay is satisfied.

Delay time will be calculated right after after dehumidification stops working.

5.4 Humidity Calibration (CA)

When there is deviation between measured humidity and actual

humidity, use humidity calibration function to align the measured humidity and actual humidity. The corrected humidity is equal to humidity before calibration plus corrected value (corrected value could be positive value, 0 or negative value).

6. Error Description

Sensor fault alarm: when humidity sensor is in a short circuit or open loop, the controller will initiate the sensor fault mode, and cancel all the actions. The buzzer will alarm, LED displays ER. Buzzer alarm could be dismissed by pressing any key. After faults solved, the system will return to normal working mode.

7. Technical Assistance and Warranty

7.1 Technical Assistance

If you have any problems on installing or using this humidity controller, please carefully and thoroughly review the instruction manual. If you require assistance, please write us to cs@inkbird.com. We will reply within 24 hours on weekdays.

You can also visit our web site www.inkbird.com to find the answers of the common technical questions.

7.2 Warranty

INKBIRD TECH. C.L. warrants this humidity controller for one years from the date of purchase when operated under normal condition by the original purchaser (not transferable), against defects caused by INKBIRD's workmanship or materials. This warranty is limited to the repair or replacement, at INKBIRD's discretion, of all or part of the thermostat. The original receipt is required for warranty purposes.

INKBIRD is not responsible for injury property damage or other consequential damages or damages of third parties arising directly from an actual or alleged in mater of workmanship of the product.

There are no representations, warranties, or conditions, express or implied, statutory or otherwise, other than herein contained in the sale of goods act or any other statue

8. Troubleshooting Guide

Issues	Causes	Solutions
The probe reading is incorrect.	<ol style="list-style-type: none"> 1. Water or condensation enters the probe. 2. The probe is placed in a area with poor humidity circulation. 3. The probe is damaged. 	<ol style="list-style-type: none"> 1. Adjust the position of the probe. 2. Use a dry cloth to clean. 3. If the probe is used in a high humidity environment, dry it using a hairdryer and then test it at room. 4. Check if the probe is intact. 5. If the deviation is small, use the CA function to calibrate.
work1 output will not turn on.	<ol style="list-style-type: none"> 1. Incorrect settings. 2. Incompatible humidifier. 3. Output malfunction. 	<ol style="list-style-type: none"> 1. Verify that the settings are correct. 2. The humidifier power is within the range of 100-240V, 10A. The humidifier can automatically turn on when plugged in. The humidifier does not have a built-in humidity control, or the built-in humidity control does not affect the IHC-200 control. 3. There is no problem with 1&2, please: <ul style="list-style-type: none"> · Unplug the controller. · Press and hold the "SET" button. · Plug the controller to power on, then release the "SET" button · Quickly press the "▲" button (do not press the "▼" button). The "work1" indicator and output should activate. If the humidifier still does not work, please contact customer service.
work2 output will not turn on.	<ol style="list-style-type: none"> 1. Incorrect settings. 2. Incompatible dehumidifier. 3. Output malfunction. 	<ol style="list-style-type: none"> 1. Verify that the settings are correct. 2. The dehumidifier power is within the range of 100-240V, 10A. The dehumidifier can automatically turn on after power is connected. The dehumidifier does not have a built-in humidity control, or the built-in humidity control does not affect the ITC-308 control. 3. There is no problem with 1&2, please: <ul style="list-style-type: none"> · Unplug the controller. · Press and hold the "SET" button. · Plug the controller to power on, then release the "SET" button · Quickly press the "▼" button (do not press the "▲" button). The "work2" indicator and output should activate. If the dehumidifier still does not work, please contact customer service.

Issues	Causes	Solutions
work1 output will not turn off.	1. Incorrect settings. 2. Humidifier power exceeds limit. 3. Output malfunction.	1. Verify that the settings are correct. 2. The humidifier power is within the range of 100-240V, 10A. 3. There is no problem with 1&2, please: ·Unplug the controller. ·Press and hold the "SET" button. ·Plug the controller to power on, then release the "SET" button · Quickly press the "▼" button (do not press the "▲" button). The "work2" indicator and output should activate. If the humidifier still does not off, please contact customer service.
work2 output will not turn off.	1. Incorrect settings. 2. Dehumidifier power exceeds limit. 3. Output malfunction.	1. Verify that the settings are correct. 2. The dehumidifier power is within the range of 100-240V, 10A. 3. There is no problem with 1&2, please: ·Unplug the controller. ·Press and hold the "SET" button. ·Plug the controller to power on, then release the "SET" button · Quickly press the "▲" button (do not press the "▼" button). The "work1" indicator and output should activate. If the dehumidifier still does not off, please contact customer service.