

INKBIRD

User Manual

CO₂ Controller

ICC-510

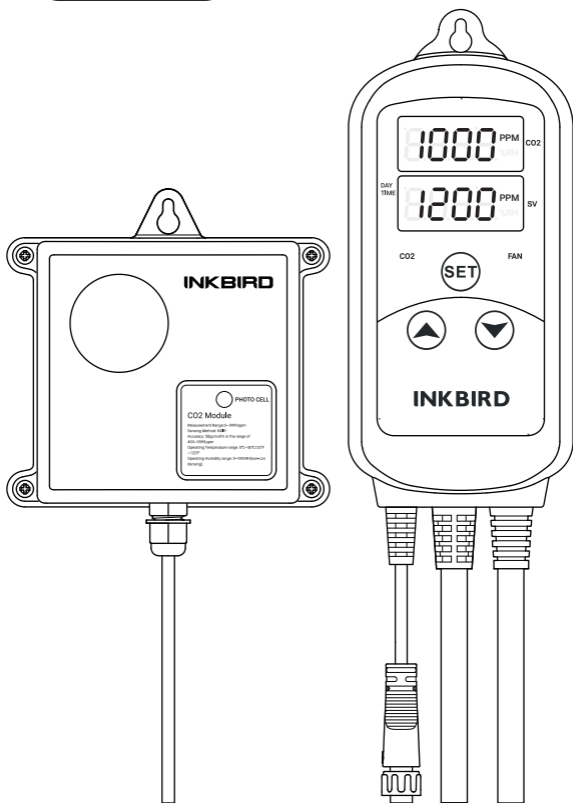



Warm tips

- To quickly jump to a specific chapter page, click on the relevant text on the contents page.
- You can also use the thumbnail or document outline in the top left corner to quickly find a specific page.



Please keep this manual properly for reference. You can also scan the QR code below to visit our official website for product usage videos. For any usage issues, please feel free to contact us at **support @inkbird.com**.

Wenn Sie eine Bedienungsanleitung in deutscher Sprache benötigen, scannen Sie bitte den QR-Code und besuchen Sie unsere Website, um sie zu erhalten und ein Video über die Verwendung des Produkts zu sehen.

Se avete bisogno di un manuale di istruzioni in italiano, scansionate il codice QR e visitate il nostro sito web per ottenerlo e vedere un video su come utilizzare il prodotto. Si vous avez besoin d'un mode d'emploi en français, veuillez scanner le code QR pour visiter notre site officiel afin d'obtenir et de visionner la vidéo d'utilisation du produit !

Als je een Nederlandstalige handleiding nodig hebt, scan dan de QR-code om naar onze officiële website te gaan en bekijk de video over het gebruik van het product!

Si necesita el manual de instrucciones en español, escanee el código QR para ir a nuestro sitio web oficial y ver el vídeo sobre cómo utilizar el producto.

CONTENTS

01 Overview	01
02 Product Diagram	01
03 Operation Instructions	04
04 Troubleshooting Guide	15
05 Technical Specifications	15
06 Important Notes/Warnings	16
07 Cleaning and Maintenance	16
08 Customer Service	16

01 Overview

The INKBIRD ICC-510 is a plug and play CO₂ controller that comes with a professional grade CO₂ sensor manufactured to ANSI/ASHRAE Standard 62.1-2022+Addendum ab (31 October 2023) RESET Grade B and provides you with Plant Mode and Human Mode for different usage scenarios. The plant mode is suitable for plant environments that require high levels of CO₂ during lighting, such as plant tents and greenhouses. In addition, it is equipped with a photo sensor to automatically detect whether there is lighting or not. The human mode is suitable for indoor environments where people are active every day. It monitors CO₂ levels throughout the day and turns on the exhaust fan when needed, creating a healthier and more comfortable living environment for you and your families.

02 Product Diagram

Notice: Do not break the white mask on the sensor as this may damage the internal components of the sensor.

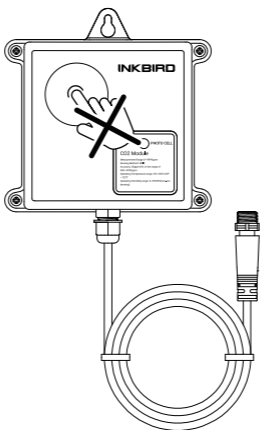

2.1 Control Panel

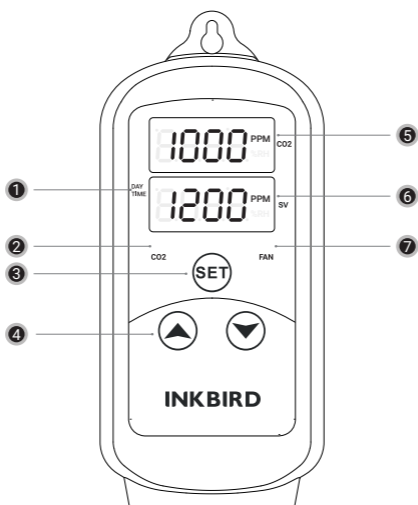

- 1 DAY TIME indicator light:** Flashes in daytime mode, dims in nighttime mode.
- 2 CO2 indicator light:** The CO2 outlet is outputting when it is lit.
- 3 SET:** Setting button; Press and hold it to enter/exit the setting mode.
- 4 ▲/▼:** In the setting mode, press to adjust the relevant parameter.
- 5 CO2 display screen:** When running, it displays the current CO2 level; when setting, it displays the set value.
- 6 SV display screen:** When running, it displays the STOP value, START value, and BoFF; When setting, it displays the character of menu.
- 7 FAN indicator light:** The FAN outlet is outputting when it is lit.

2.2 Outlet

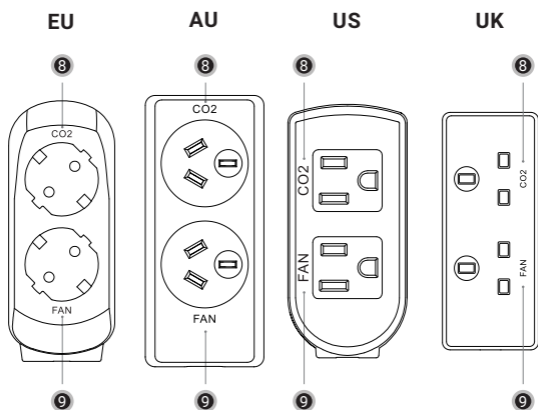

⑧ CO2: Plug the CO2 device into this outlet.

⑨ FAN: Plug the air ventilation fan into this outlet.

2.3 Product Size and Cords

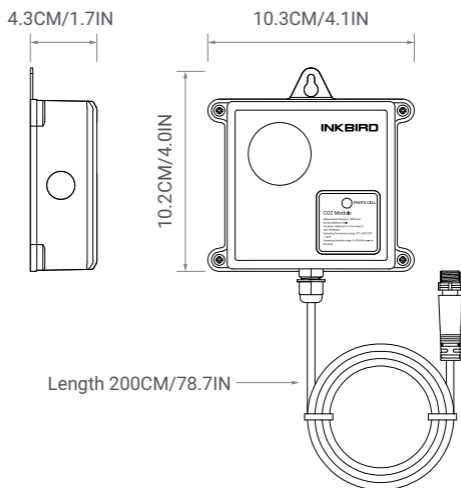

3.5CM/1.4IN



7.2CM/2.8IN

16.2CM/6.4IN

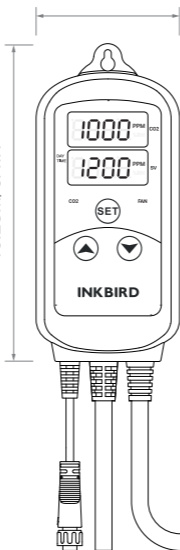

Length 150CM/95IN

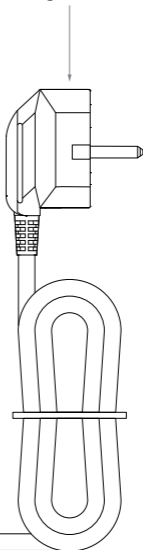

03 Operation Instructions

3.1 Install CO2 Sensor

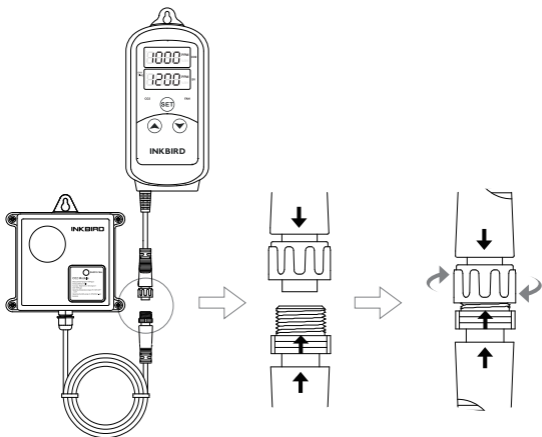

3.2 Power On

Plug the controller to a power source.

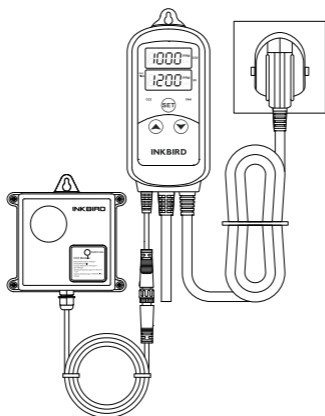

- 1) The screen will first display **8888** .
- 2) Wait for 3 seconds, it will display **----** .
- 3) Wait for 3 seconds again, it will display numeric values.

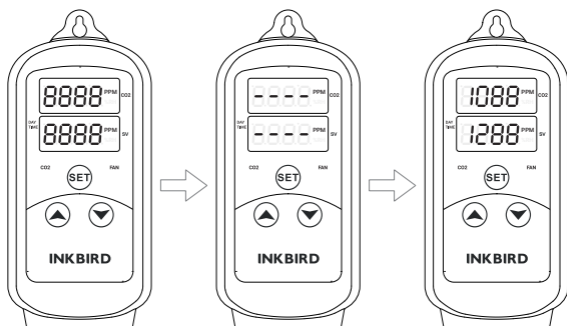

3.3 Menu and Symbols

SV Display Screen	Meaning	CO2 Display Screen	Function Description	Range
CF (CF)	CO2 or Fan	CO2 (CO2)	Plant mode without fan, see 3.4.1	/
		both (both)	Plant mode with fan, see 3.4.2	
		FAN (FAN)	Human mode, see 3.4.3	
Con (Con)	CO2 on value	1200ppm (custom)	When CO2 ≤ 1200ppm, the CO2 outlet is on.	0~9950 ppm
CoFF (CoFF)	CO2 off value	1600ppm (custom)	When CO2 ≥ 1600ppm, the CO2 outlet is off.	50~9999 ppm
Fon (Fon)	Fan on value	2000ppm (custom)	When CO2 ≥ 2000ppm, the FAN outlet is on.	50~9999 ppm
FoFF (FoFF)	Fan off value	1600ppm (custom)	When CO2 ≤ 1600ppm, the FAN outlet is off.	0~9950 ppm
CAL (CAL)	Calibration	0 (custom)	See 3.5.1	-200~200 ppm
ALn (ALM)	Alarm	ON (ON)	The high/low level alarm value to turn on the CO2 unit	/
		OFF (OFF)	The high/low level alarm value to turn off the CO2 unit	
AH (AH)	Alarm high value	9999ppm (custom)	When CO2 ≥ 9999ppm, it beeps.	50~9999 ppm
AL (AL)	Alarm low value	0 (custom)	When CO2 ≤ 0ppm, it beeps.	0~9950 ppm
PCAL (PCAL)	Professional calibration	400ppm (custom)	See 3.5.2	0~9900 ppm

3.4 Program the Parameters

Determine what device you want to control:

- 1) Only controls CO2 devices, such as a CO2 regulator or generator (See section 3.4.1 Plant Mode without Fan);
- 2) Simultaneously controls CO2 device and ventilation fan (See section 3.4.2 Plant Mode with Fan);
- 3) Only controls ventilation fans (See section 3.4.3 Human Mode).

3.4.1 Plant Mode without Fan

Only for CO2 devices, such as a CO2 regulator or generator. (For Human Mode, see section 3.4.3)

NOTE: Please note that the photo sensor only works for the CO2 outlet. When there is light, it will turn the CO2 outlet on/off based on the set values; when there is no light, it will keep the CO2 outlet off regardless of the set values.

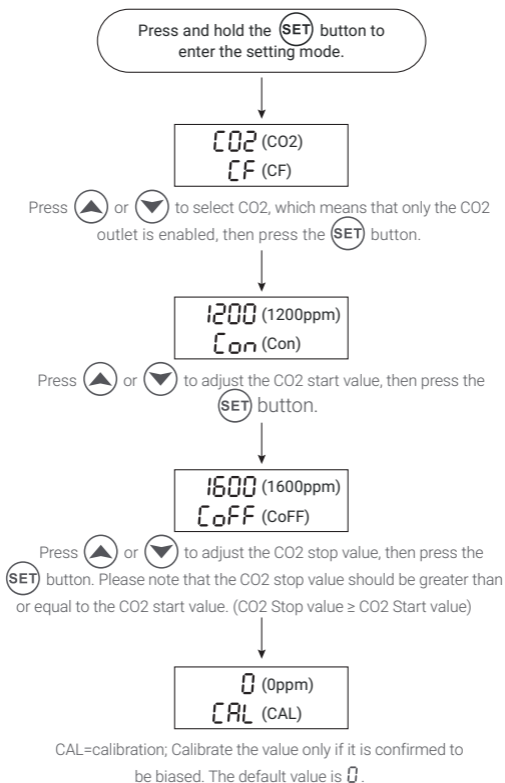

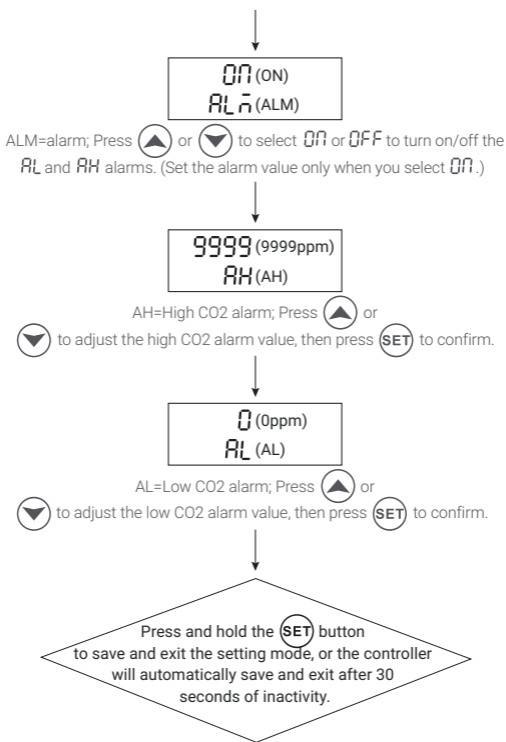

In setting mode, it displays the menu character; when running with the CO2 indicator light on, it displays the stop value, prompting you when to turn off; when running with the CO2 indicator light off, it displays the start value, prompting you when to start.

3.4.2 Plant Mode with Fan

Use the CO2 device and ventilation fan at the same time. (For human mode, please see section 3.4.3)

NOTE: Please note that the photo sensor only works for the CO2 outlet. The Fan outlet is turned on or off based on the set values, regardless of the light.

Press and hold the **SET** button to enter the setting mode.

botH (botH)
[F (CF)

Press **▲** or **▼** to select **botH**, which means that both the CO2 and fan outlets are enabled, then press the **SET** button.

1200 (1200ppm)
[on (Con)

Press **▲** or **▼** to adjust the CO2 start value, then press the **SET** button.

1600 (1600ppm)
[oFF (CoFF)

Press **▲** or **▼** to adjust the CO2 stop value, then press the **SET** button. Please note that the CO2 stop value should be greater than the CO2 start value. (CO2 Stop value > CO2 Start value)

2000 (2000ppm)
Fon (Fon)

Press **▲** or **▼** to adjust the FAN start value, then press the **SET** button. Please note that the FAN start value should be greater than or equal to the CO2 stop value. (FAN Start value \geq CO2 Stop value)

1600 (1600ppm)
FoFF (FoFF)

Press **▲** or **▼** to adjust the FAN stop value, then press the **SET** button. Please note that the FAN stop value should be smaller than the FAN start value. (FAN Stop value < FAN Start value)

0 (0ppm)
[AL (CAL)

CAL=calibration; Calibrate the value only if it is confirmed to be biased. The default value is 0.

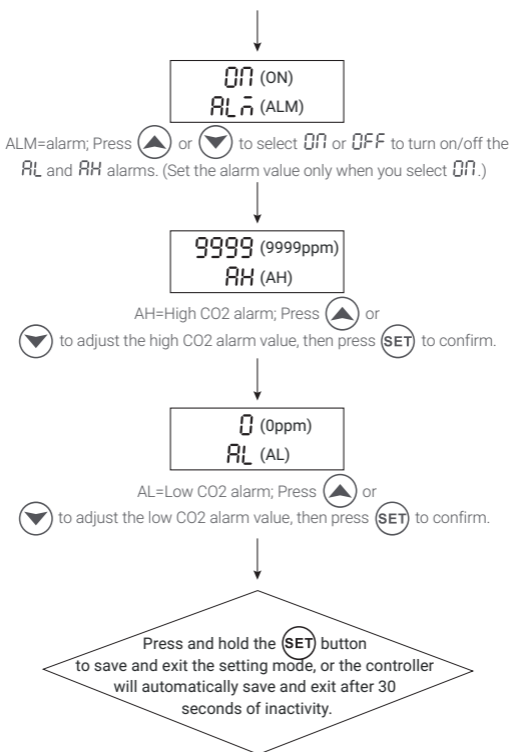

In setting mode, it displays the menu character; when running with the CO2 indicator light on, it displays the CO2 stop value; when running with the FAN indicator light on, it displays the FAN stop value; when both the CO2 and FAN indicator lights are dimmed, it displays *both*.

3.4.3 Human Mode

Only use for ventilation fans. (For plant mode, please see section 3.1 or 3.2).

NOTE: Please note that the fan outlet is turned on or off based on the set values regardless of the light.

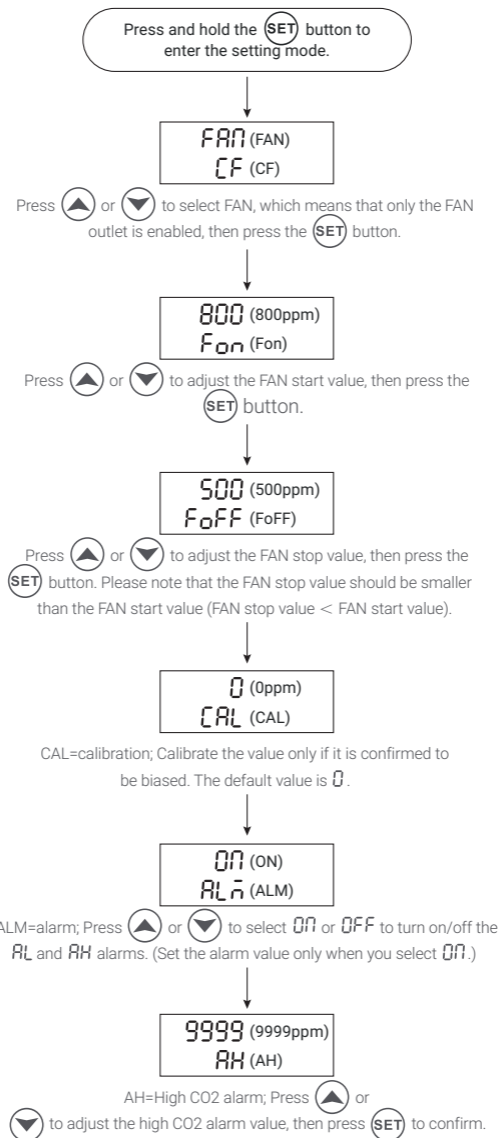

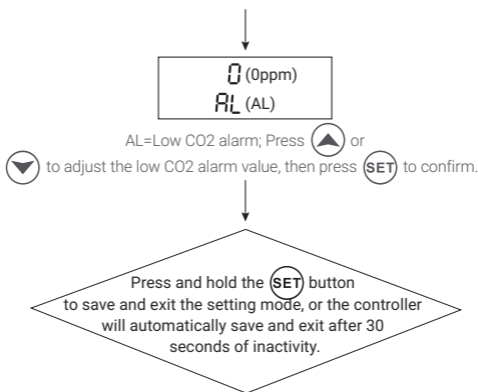

In setting mode, it displays the menu character; when running with the FAN indicator light on, it displays the stop value, prompting you when to stop; when running with the FAN indicator light off, it displays the start value, prompting you when to start.

3.5 CO2 Calibration

3.5.1 General Calibration

- 1) Press and hold the SET button for 2 seconds to enter the setting mode.
- 2) Press the SET button to change the menu, then press ▲ or ▼ to adjust the parameter when the SV screen displays CAL.
- 3) Finally, press and hold the SET button for 2 seconds to save and exit the setting.
- 4) The value after calibration = the value before calibration + the calibration value

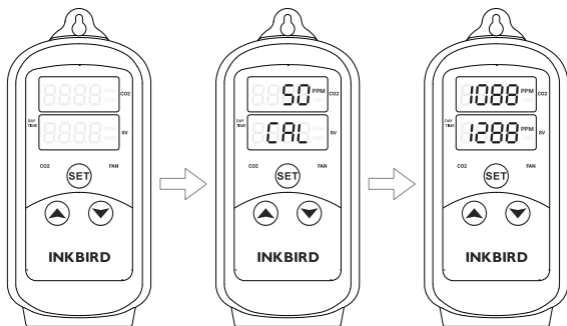

3.5.2 Professional Calibration

NOTE: Please place the CO2 sensor in an environment with a stable CO2 level, otherwise the calibration time may be prolonged or the calibration may fail. If the CO2 level in the current environment fluctuates greatly, please use the general calibration.

1) With the controller running, press and hold the ▲ and ▼ buttons simultaneously for 2 seconds until the SV screen displays *PCAL* and the CO2 screen displays 400ppm (default), then release both buttons.

2) Then, press ▲ or ▼ to adjust the parameter.

3) After confirmation, press and hold the **SET** button for 2 seconds to start calibration, the CO2 screen will display ---- and flash.

4) Calibration takes 1 to 20 minutes. Please be patient.

5) It is recommended to calibrate to 400ppm in a ventilated outdoor environment or to a number that matches the known CO2 rated value.

6) Calibration Result:

- If the CO2 screen displays *PASS* and the SV screen displays *PCAL*, the calibration is successful. Press any button to exit.
- If the CO2 screen displays *FAIL* and the SV screen displays *PCAL*, the calibration has failed. Perform the calibration again or press any button to exit.

NOTE: When the CO2 sensor is performing automatic calibration, with the SV screen displaying ---- and flashing, do not exhale into the sensor.

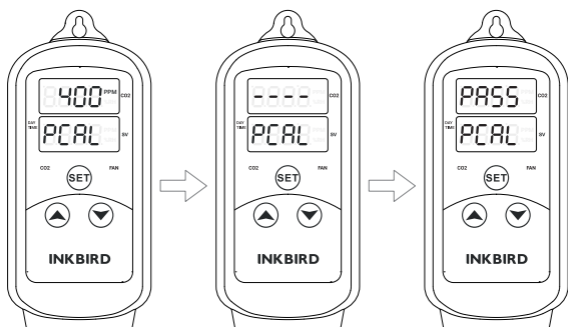

3.6 Alarm Setting

3.6.1 Enable the audible alarm

1) When running, press and hold the **SET** button for 2 seconds to enter the setting mode.

- 2) Press the **SET** button to switch to $AL\bar{n}$.
- 3) Press \blacktriangle or \blacktriangledown to select $0\bar{n}$.
- 4) Then, set the RH and RL alarm values using the same method.

NOTE: If the device is sounding an alarm, press any button to stop the alarm.

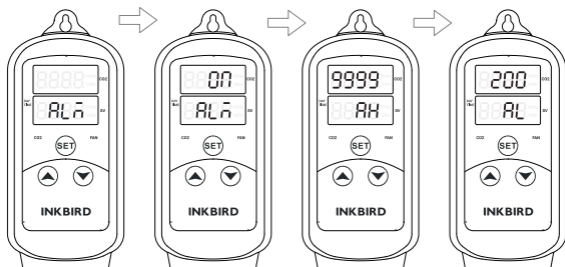

3.6.2 Disable the audible alarm

- 1) When running, press and hold the **SET** button for 2 seconds to enter the setting mode.
- 2) Press the **SET** button to switch to $AL\bar{n}$.
- 3) Then, press \blacktriangle or \blacktriangledown to select OFF .

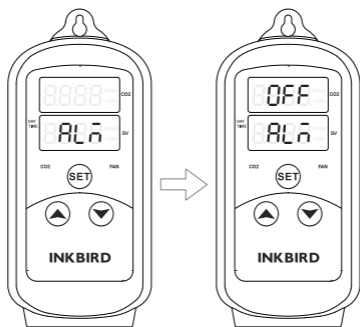

3.7 Factory Reset

Disconnect the controller from the power supply, then reconnect it while pressing and holding the \blacktriangledown button until you hear a beep, which means the factory reset is successful. You can then release the \blacktriangledown button and the screen will return to normal in a few seconds.

04 Troubleshooting Guide

NO.	Issues	Causes	Solutions
1	Displaying Er	1). The CO2 sensor is not plugged in. 2). The CO2 sensor has a poor connection.	Please properly insert the CO2 sensor.
2	Displaying ----- / 8888	1). This is normal when the controller is just turned on. 2). The power supply to the controller is unstable. 3). It is normal for ----- to flash during professional calibration.	1). Please wait for 6 seconds. 2). Make sure the controller's power plug is properly inserted into the power outlet. 3). Please wait for 1 to 20 minutes.
3	The output cannot be turned on or off.	1). The connected device has a poor connection or is damaged. 2). The relay has a malfunction.	1). Make sure that the device is properly plugged into the controller receptacle and that the device is not damaged. 2). Please contact customer support.
4	Incorrect CO2 readings	The CO2 measurement is incorrect.	Press and hold the (SET) button to enter the setting mode and select CAL to perform calibration.
5	Displaying FAIL PCAL during calibration	Calibration failed because the CO2 concentration in the environment where the sensor is located varies greatly.	Please place the sensor in an environment with a stable CO2 level for calibration.

05 Technical Specifications

5.1 Controller

- Brand: INKBIRD
- Model Number: ICC-510
- Input Power: 100~240Vac 50/60Hz 10A MAX
- Output Power: 100~240Vac 50/60Hz 10A MAX
- Operating Environment Temperature: Room temperature
- Storage Environment Temperature: 0°C~60°C/32°F~140°F
- Storage Environment Humidity: 20~80%RH (unfrozen or non-condensing state)

5.2 CO2 Sensor

- Measurement Interval: 5s
- Measurement Range: 0~9999 ppm
- Sensing Method: NDIR
- Error Range: 50ppm±5% in the range of 400~9999ppm

- **Operating Temperature:** 0°C~50°C/32°F~122°F
- **Operating Humidity:** 0~95%RH (non-condensing)
- **Standard:** ANSI/ASHRAE standard 62.1-2022
+Addendum ab (October 31, 2023) RESET grade B

06 Important Notes/Warnings

To ensure proper and safe use of this product, please read this manual carefully and thoroughly before using the CO2 Controller. These warnings contain important safety information that should be followed during use:

- Keep the device away from children and out of their reach.
- Do not subject the device to shock or vibration as this may affect the accuracy of the sensor.
- Do not place the device or the power plug near a heat source. Heat will deform the device and cause a fire.
- Do not disassemble the CO2 controller or touch exposed electronic circuitry as this may result in an electric shock.
- Connect the controller only to a grounded power outlet. Failure to do so may result in serious damage to the product or personal injury or death to the user.

07 Cleaning and Maintenance

- The white mask on the CO2 sensor must remain intact. Do not break the white mask as this may damage the internal components of the sensor.
- Keep both the photo sensor and CO2 sensor away from dust. Periodically use a dry cloth to remove dust to prevent light sensing malfunctions, erroneous CO2 readings, and slow response.
- Do not cover the photo sensor or seal the CO2 sensor during use, as this may cause the device to fail to operate normally.
- When not in use, clean the product immediately and store in a dry place.

08 Customer Service

The controller is warranted for 2 years (5 years for the CO2 sensor) against defects in either components or workmanship. During this period, products that prove to be defective will, at the discretion of INKBIRD, be either repaired or replaced without charge. For any problems in use, please feel free to contact us at support@inkbird.com. We will do our best to help you.

Shenzhen Inkbird Technology Co.,Ltd.

support@inkbird.com

Consignor: Shenzhen Inkbird Technology Co., Ltd.

Office Address: Room 1803, Guowei Building, No.68 Guowei Road,
Xianhu Community, Liantang, Luohu District, Shenzhen, China

Manufacturer: Shenzhen Inkbird Technology Co., Ltd.

Factory Address: 6th Floor, Building 713, Pengji Liantang Industrial
Area, No.2 Pengxing Road, Luohu District, Shenzhen, China



V1.0

MADE IN CHINA

DESIGNED BY INKBIRD

